



AS-6P30 BLACK

POLYCRYSTALLINE MODULE



ADVANCED PERFORMANCE & PROVEN ADVANTAGES

- ☒ Aesthetically appealing design with black backsheet and frame.
- ☒ High module conversion efficiency up to 17.52% by using high efficient solar cells and advanced manufacturing technology.
- ☒ Low degradation and excellent performance under high temperature and low light conditions.
- ☒ Robust aluminum frame ensures the modules to withstand wind loads up to 2400Pa and snow loads up to 5400Pa.
- ☒ High reliability against extreme environmental conditions (passing salt mist, ammonia and hail tests).
- ☒ Potential induced degradation (PID) resistance.
- ☒ Positive power tolerance of 0 ~ +3 %.

CERTIFICATIONS

- ☒ IEC61215, IEC61730, IEC62716, IEC61701, CE, CQC, CGC, ETL(USA), JET(Japan), J-PEC(Japan), Kemco(South Korea), KS(South Korea), MCS(UK), CEC(Australia), FSEC(FL-USA), CSI Eligible(CA-USA), Israel Electric(Israel), InMetro(Brazil), TSE(Turkey)
- ☒ ISO9001:2015: Quality management system
- ☒ ISO14001:2015: Environmental management system
- ☒ OHSAS18001:2007: Occupational health and safety management system

SPECIAL WARRANTY

- ☒ 12 years limited product warranty.
- ☒ Limited linear power warranty: 12 years 91.2% of the nominal power output, 30 years 80.6% of the nominal power output.

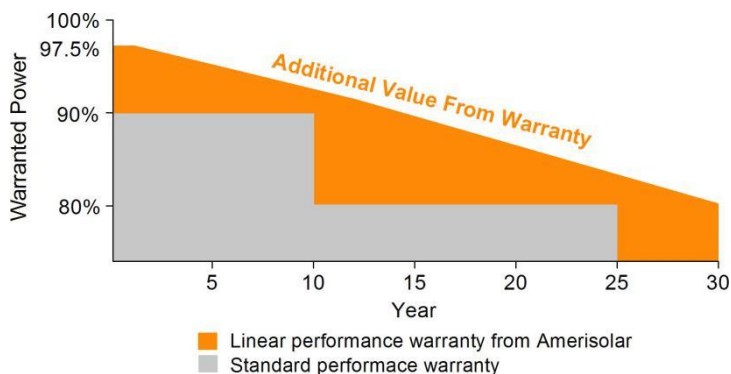

Passionately
committed to
delivering innovative
energy solution



ELECTRICAL CHARACTERISTICS AT STC

Nominal Power (P_{max})	250W	255W	260W	265W	270W	275W	280W	285W
Open Circuit Voltage (V_{oc})	38.0V	38.1V	38.2V	38.3V	38.4V	38.5V	38.6V	38.7V
Short Circuit Current (I_{sc})	8.75A	8.83A	8.90A	8.98A	9.09A	9.20A	9.31A	9.42A
Voltage at Nominal Power (V_{mp})	30.3V	30.5V	30.7V	30.9V	31.1V	31.3V	31.5V	31.7V
Current at Nominal Power (I_{mp})	8.26A	8.37A	8.47A	8.58A	8.69A	8.79A	8.89A	9.00A
Module Efficiency (%)	15.37	15.67	15.98	16.29	16.60	16.90	17.21	17.52
Operating Temperature	-40°C to +85°C							
Maximum System Voltage	1000V DC							
Fire Resistance Rating	Type 1(in accordance with UL1703)/Class C(IEC61730)							
Maximum Series Fuse Rating	15A							

STC: Irradiance 1000W/m², Cell temperature 25°C, AM1.5

ELECTRICAL CHARACTERISTICS AT NOCT

Nominal Power (P_{max})	184W	188W	191W	195W	199W	202W	206W	210W
Open Circuit Voltage (V_{oc})	35.0V	35.1V	35.2V	35.3V	35.4V	35.5V	35.6V	35.7V
Short Circuit Current (I_{sc})	7.09A	7.15A	7.21A	7.27A	7.36A	7.45A	7.54A	7.63A
Voltage at Nominal Power (V_{mp})	27.6V	27.8V	27.9V	28.1V	28.3V	28.5V	28.7V	28.9V
Current at Nominal Power (I_{mp})	6.67A	6.77A	6.85A	6.94A	7.04A	7.09A	7.18A	7.27A

NOCT: Irradiance 800W/m², Ambient temperature 20°C, Wind Speed 1 m/s

MECHANICAL CHARACTERISTICS

Cell type	Polycrystalline 5BB 156.75x156.75mm (6x6inches)
Number of cells	60 (6x10)
Module dimensions	1640x992x35mm (64.57x39.06x1.38inches)
Weight	18kg (39.7lbs)
Front cover	3.2mm (0.13inches) tempered glass with AR coating
Frame	Anodized aluminum alloy
Junction box	IP67, 3 diodes
Cable	4mm ² (0.006inches ²), 900mm (35.43inches)
Connector	MC4 or MC4 compatible

TEMPERATURE CHARACTERISTICS

Nominal Operating Cell Temperature (NOCT)	45°C±2°C
Temperature Coefficients of P_{max}	-0.41%/°C
Temperature Coefficients of V_{oc}	-0.31%/°C
Temperature Coefficients of I_{sc}	0.05%/°C

PACKAGING

Standard packaging	30pcs/pallet
Module quantity per 20' container	360pcs
Module quantity per 40' container	840pcs(GP)/924pcs(HQ)

ENGINEERING DRAWINGS

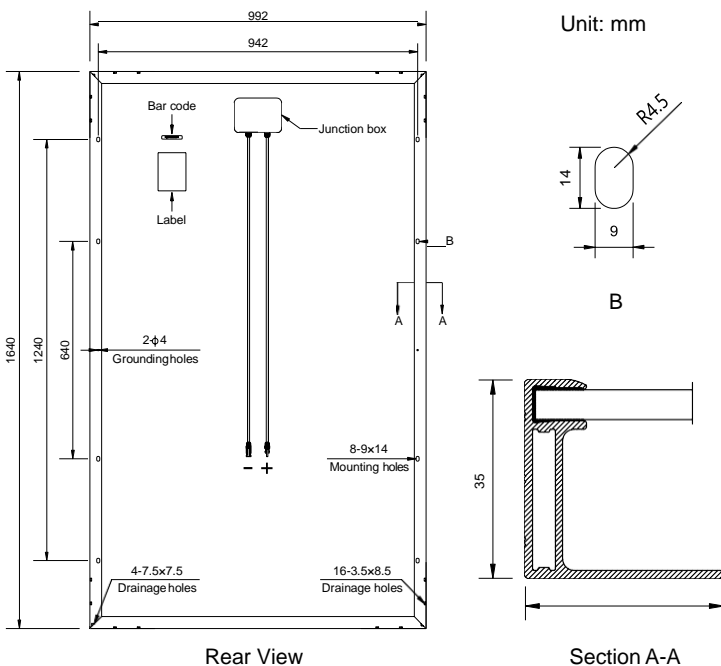

IV CURVES

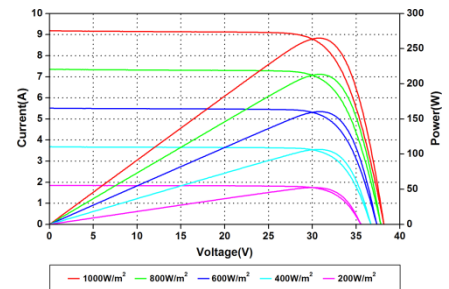

Current-Voltage and Power-Voltage Curves at Different Irradiances

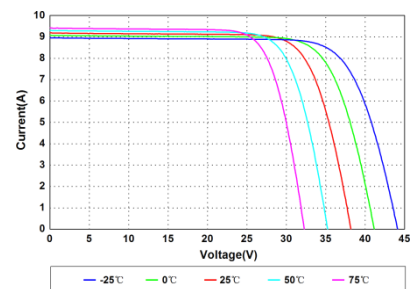

Current-Voltage Curves at Different Temperatures

Specifications in this datasheet are subject to change without prior notice.